

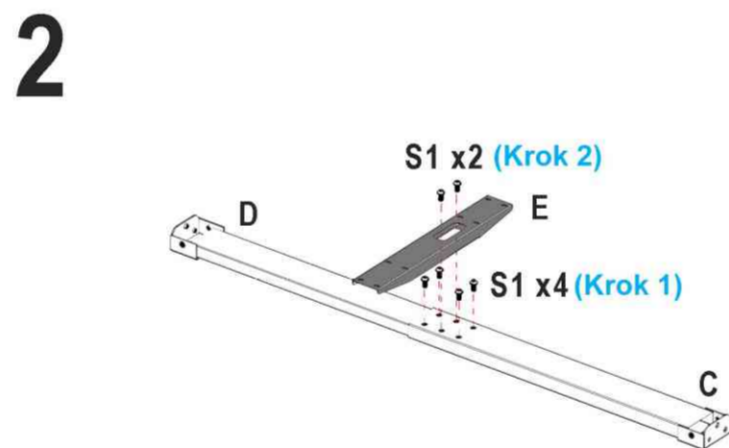

# ULTRADESK®

## FRAG XXL

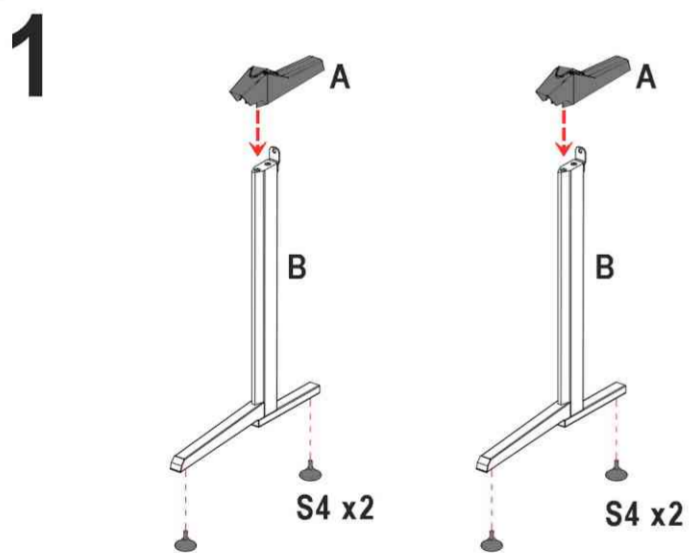
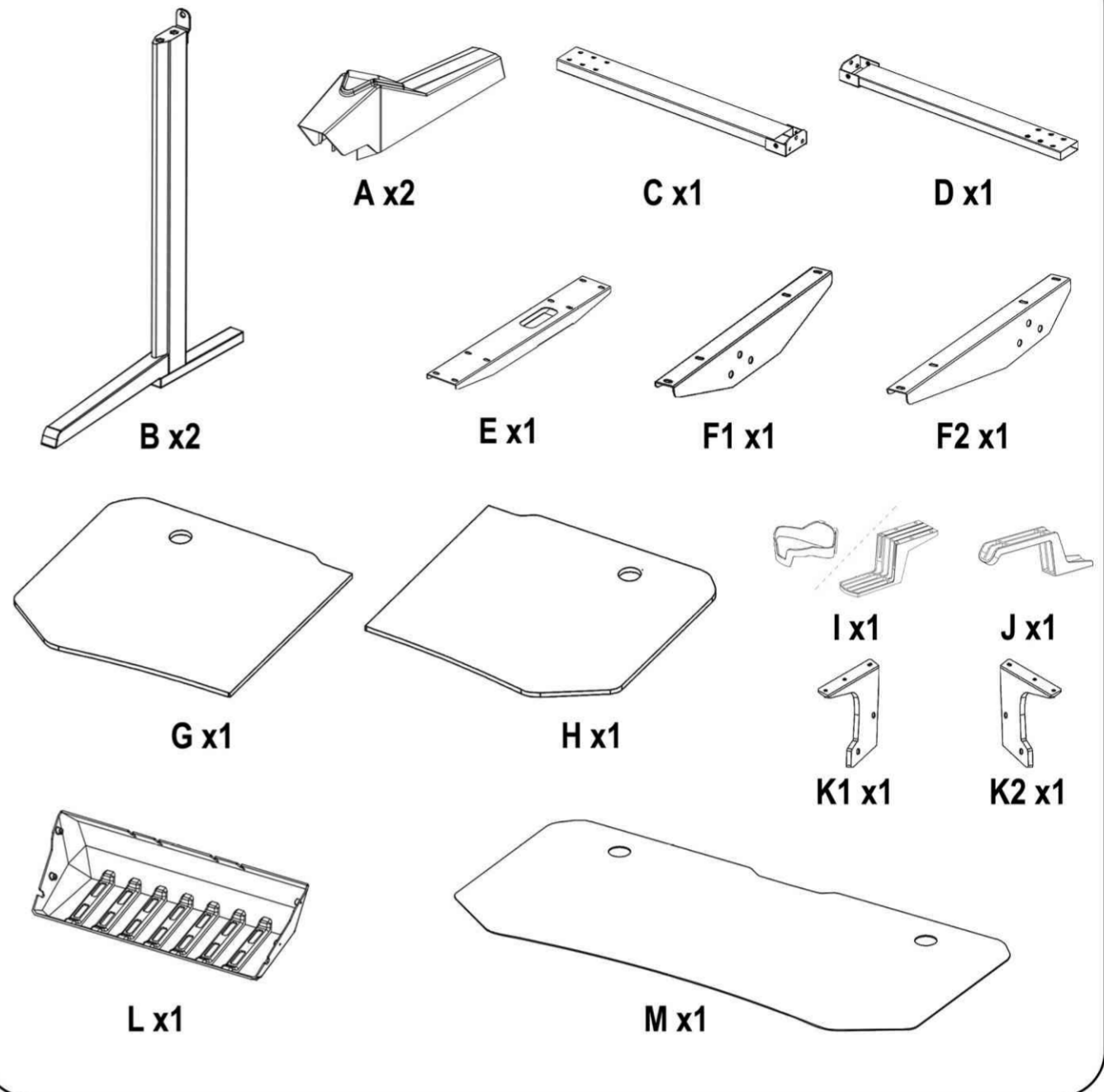
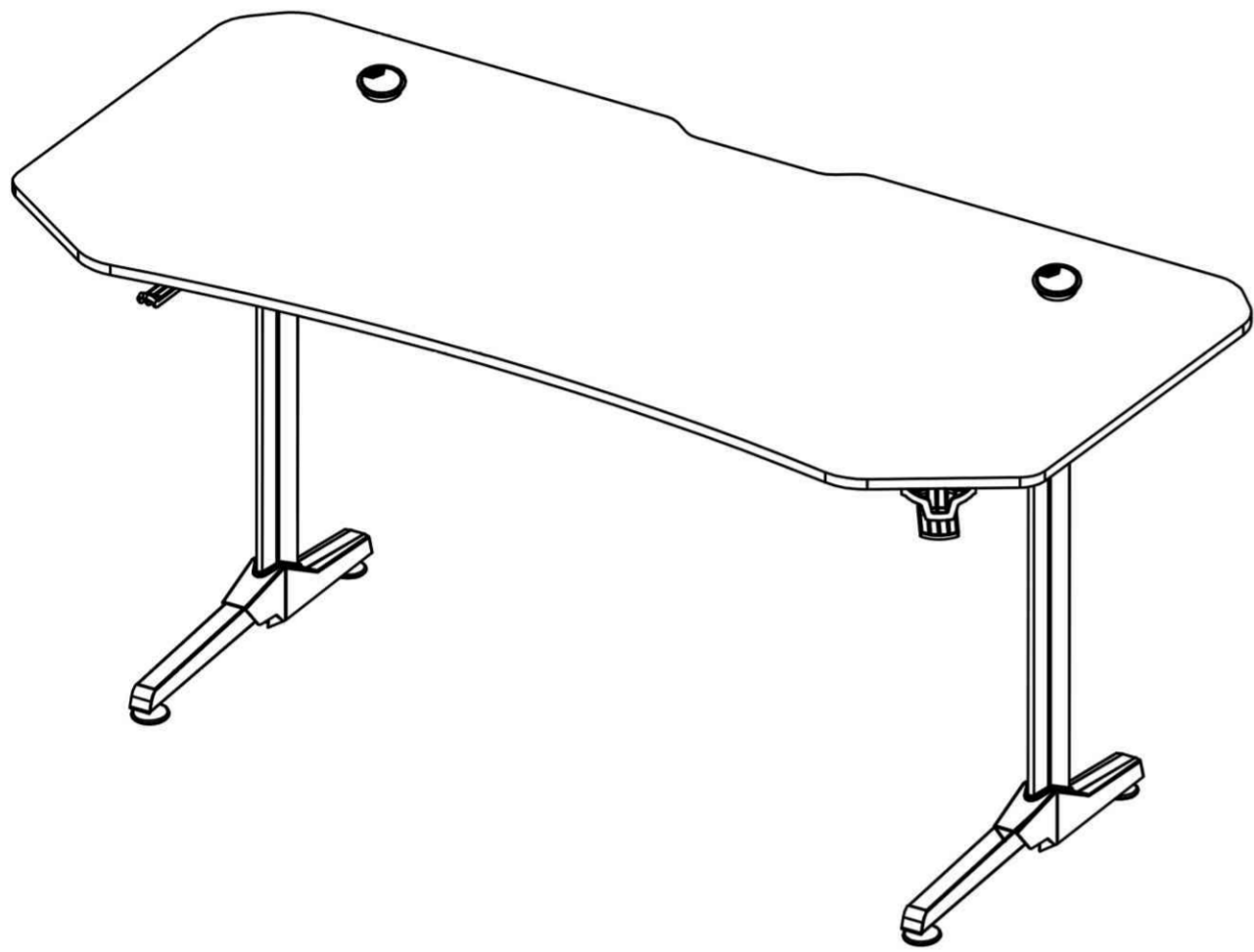
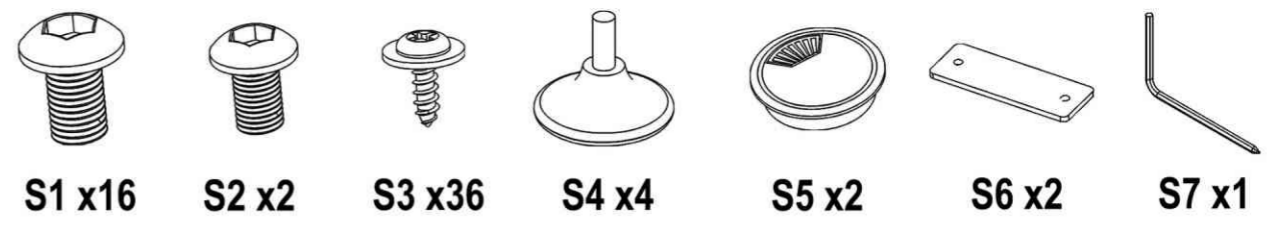

Upewnij się, że część E jest prostopadła do części C-D.

